



GX Group

GalleryX[®] erweckt Wände & Decken zum Leben

A black and white photograph showing a close-up of several UHPC 3D tiles. The tiles are arranged in a grid pattern, with each tile having a distinct, rounded, dome-like shape. The lighting creates strong highlights and shadows, emphasizing the three-dimensional texture and the smooth surface of the tiles.

UHPC 3D TILES



1



2



3



4



5



6



7

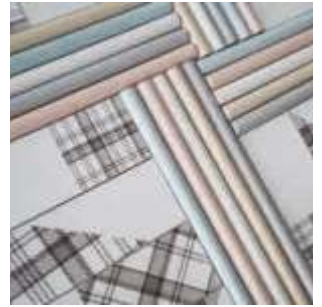

8



9



10



11

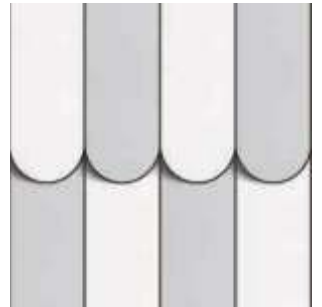

12



13



14



15



16



17



18



19



20



21



22



23



24



25



26



27



28



29



30



31



32



1



2



3



4



5



6



7



8



9



10



11

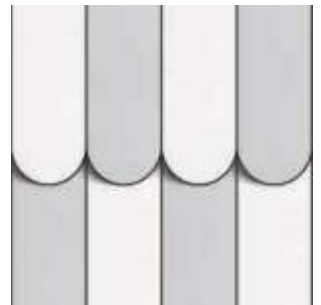

12



13



14



15



16



17



18



19



20



21



22



23



24



25



26



27



28



29



30



31



32



GX Group Materials is a fine concrete design and manufacturing company focusing on innovation. Its novel concept and manufacturing space include the creation of contemporary concrete architecture and design elements, which makes the material upgrade from the industrial source. The company's manufacturing focus is to explore the customized design of concrete by developing new intelligent materials and aesthetic characteristics, and to create new value in interior design by using its logic.



UHPC 3D TILES

YACHT

1

ORIGINAL DESIGN



60T WHITE



10C GRAY



BI-01

The yacht is like a swan spreading its wings in the wind, sliding smoothly on the water surface. A clean, beautiful and light yacht is sliding in the light fog at dusk, fast and beautiful, leaving a luminous water mark behind. The inspiring moment is from yacht shape and hope it will give the featured wall a new feeling.

40 mm



125 mm

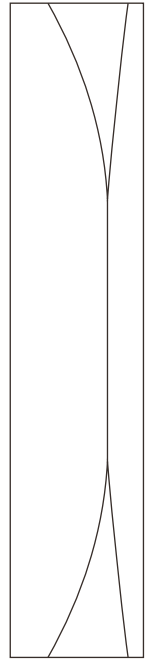

600 mm

FEATHER

2

ORIGINAL DESIGN



60T WHITE



10C GRAY



100CM

The implication is elegant, civilized, brave, the colorful gorgeous feathers give people the visual enjoyment, let people sigh over the creativity of nature. This beautiful and mysterious feather shape that gives the concrete a strong artistic sense, adds dynamism and interest to it, and creates a special and stylish space, which is not only a visual enjoyment, but also a sense of spatial ceremony. Feather itself of the threads, perfectly reflected on the surface of the concrete, that is not only the beauty of modeling shape, but also has cultural meaning, art from life, but higher than the life.

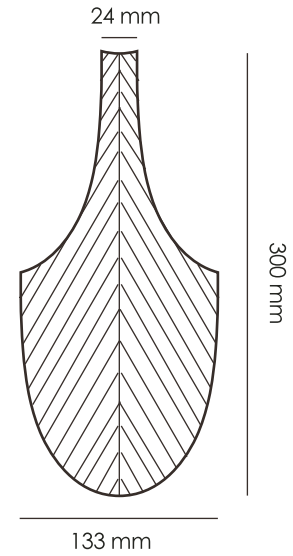



ORIGINAL DESIGN

WATERDROP



WD-001



WD-007



WD-008



WD-006



WD-003

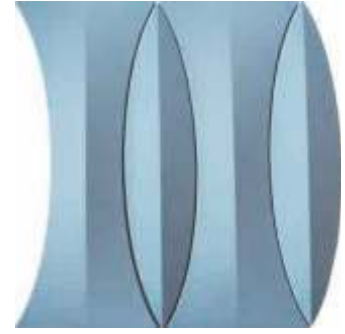

WD-005

Water drops into the mud, silent, like tears, like the sigh of the soul, more like the hint of fate, to retain the shape of the last flower. Waterdrop design is bold. 2 parts combined into a beautiful shape.

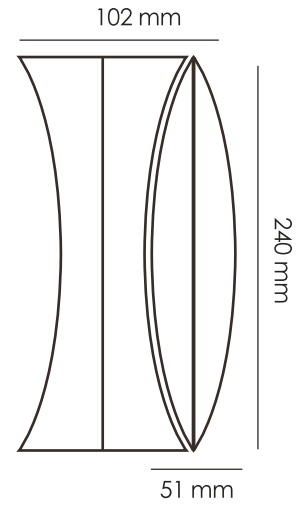



60 T WHITE



10C GRAY

It implies freedom, dream and beautiful, expressing people's yearning and pursuit for a happy life. The artistic design sense of this kind of kite brings interesting and vivid visual elements. While enriching the sense of space levels, it also adds the power of people's imagination and longing for hope, and touches the heart. kite flies against the wind, not down the wind.

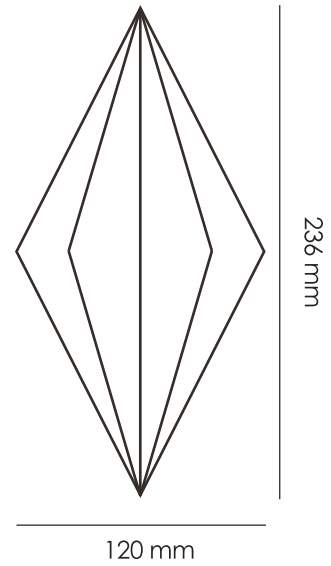



60 T WHITE



10C GRAY

The pentagonal polygon, which means self exploration, diversity and creativity, expresses people's desire for inner freedom by breaking through the traditional limitations, boldly subverting. The challenging irregular Pentagon, with its unique geometric elements, brings a unique balance in the space design, and at the same time, it is full of interest. It breaks some traditional shackles, and forms a strong sense of combination. This is the essence of "simplicity but not simple".

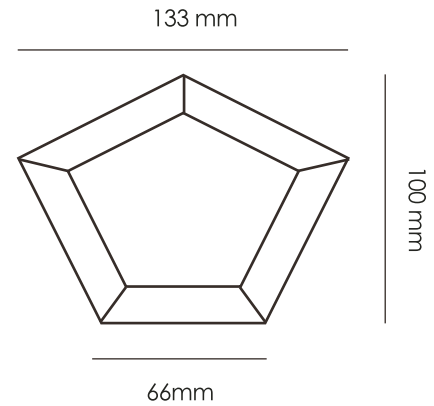

DUNE



ORIGINAL DESIGN

Dunes are composed of elegantly drawn out subway tiles sculpted with an offset angled surface. This creates a modern tapering trapezoid relief that dances across the surface. Meshed in a straight stack pattern, Dune tiles are successively placed to create an exclusive finished surface. flies against the wind, not down the wind.

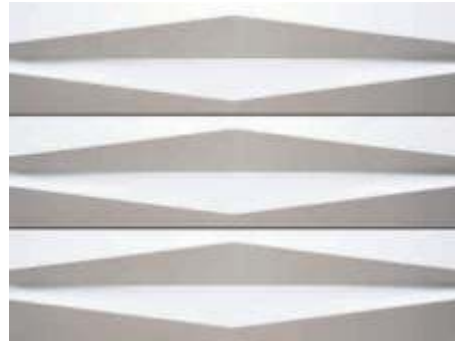

60 T WHITE



10 C GREY

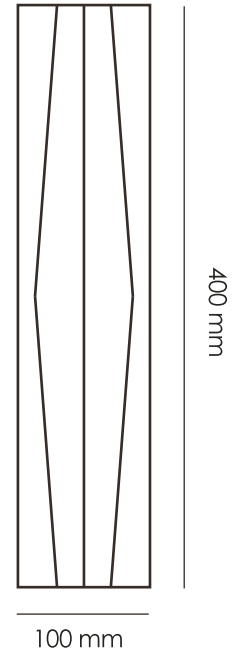



60T WHITE



GOLD



SILVER

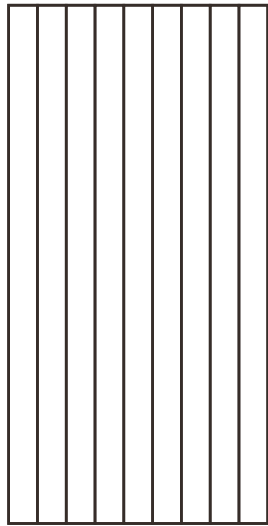

225 mm

450 mm

The design of APEX gives the featured wall a sense of modernity. Deep triangular grooves reveal the plasticity of tiles for project.

APEX

7

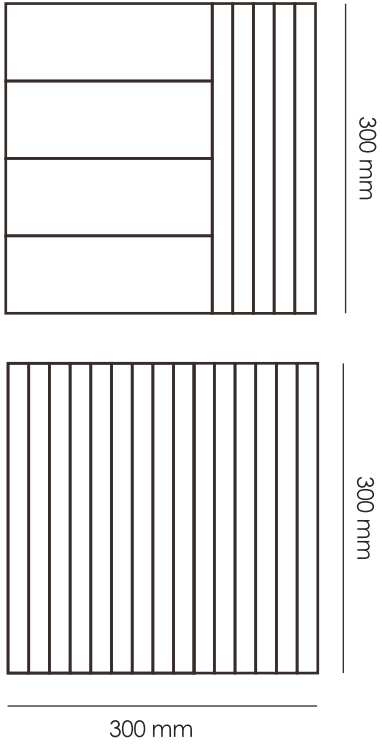

The design of f BAR is made by our designer and free style mixed two elements gives the wall in more creative choice.

BAR

ORIGINAL DESIGN





MN-001



MN-002

Inspired by the architecture of Milan, Italy, it contains concrete, marble and metal. Three elements, showing extremely noble wall design.

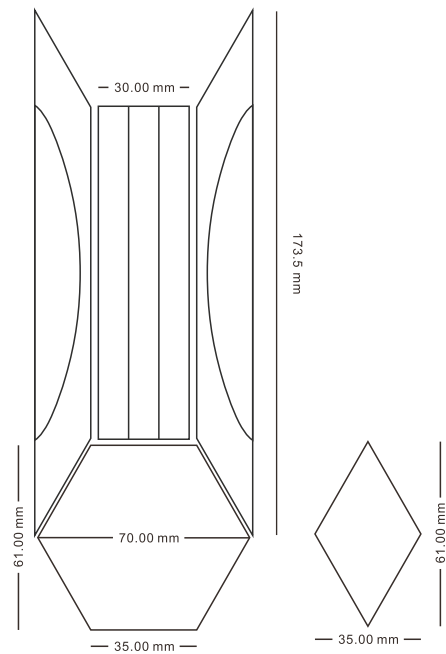

10

ORIGINAL DESIGN

WINGS



60 T WHITE



10C GRAY

Wings finds its genesis in the span and spread of flying wings. The design combines the visual tension created by the wind under the wings with the easiness of flying up in the sky. The highly decorative silhouette enhances the creative value of the space by presenting an artistically unique and unified look. The design featured in lights adds extra multi-dimensions and depth to the original shape, enhancing the appealing visual impact to a greater extent.

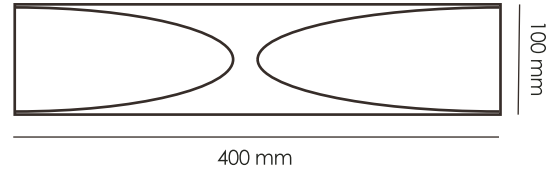

WINDOW

11

ORIGINAL DESIGN

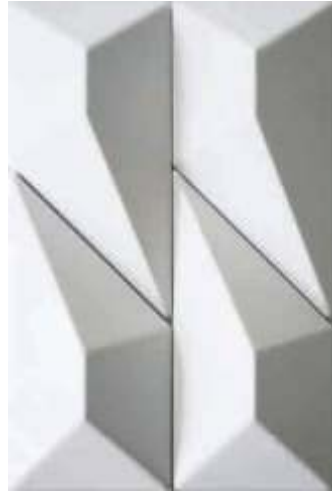

60 T WHITE



10C GRAY

The window shows a rich and broad world for people, the creative eye-catching abnormality three-dimensional full of high fashion sense, the design level of not limited to one pattern changed the plain, give people the impression of pursuing exploration and new ideas, add the unique personality charm for the aesthetic feeling of the space.

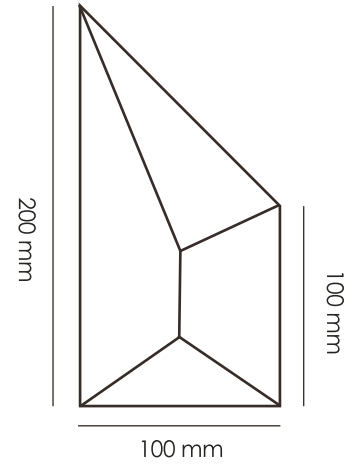

SCALES

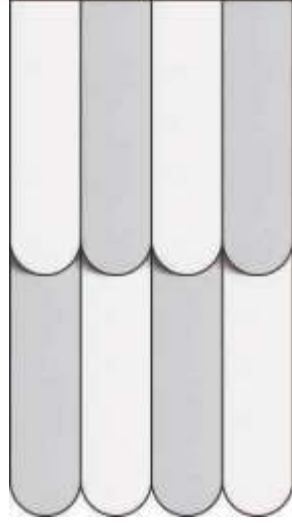

SC-001



SC-003

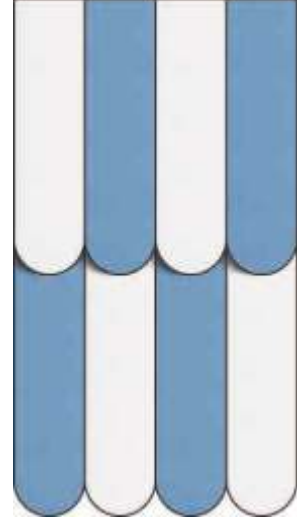

SC-002

Inspired by a mermaid scales, clever and unique design sense, gather the wisdom of imagination, cleverly create a unique artistic style, give a space dream magical characteristic, scales like the curve of the leap, like the flow of corrugated, colorful combination, the integration of nature and the modern, vivid and interesting ideal spaciousness.

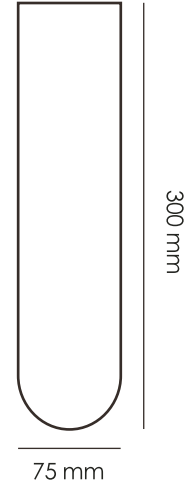



10C GREY + 60T WHITE



10N BLUE + 60T WHITE

The design inspiration comes from the colorful fireworks, the 3D design and the vivid and interesting combination collocation endue the clever sense of space, the distinct pattern presents the dynamic visual aesthetic feeling. Like a clever fireworks, in the vast space to bloom, so that everyone has a look at the universe of romantic feelings.

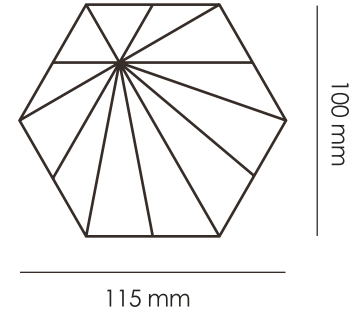

14

FLOWER

ORIGINAL DESIGN



60 T-WHITE



60 T-WHITE + GOLD

The flower shape, which implies elegance, beauty and blessing, is inspired by the wonderful ornament of nature, and brings unique artistic sense to the space design with the blooming characteristics of fresh and free from vulgarity and elegant posture. This collision of nature and fashion brings people pleasure and aesthetic enjoyment, and brings full vitality and high quality to the living space.

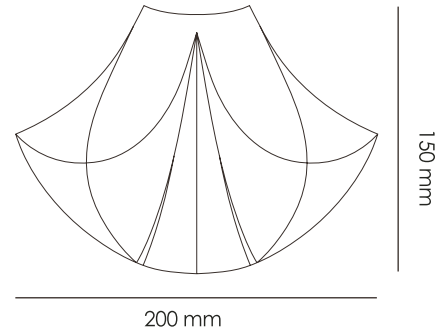



10 BLUE



10 C GREY



10 C BLUE



10 S GREY



UC WHITE



30 C GREY



10 P GREEN



10 ROYAL

The cement tile in three-dimensional hexagon has unique geometric elements, the personalized collocation of 3D surface and plain surface effect, the sense of combination of non-binding style and fun, forms a very appealing visual shock, and brings a unique balance in the space design, thus bringing people the "contracted but not simple" space enjoyment.

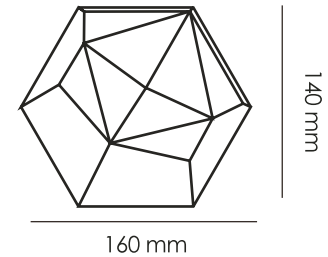
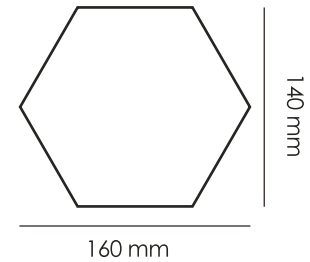

16

ORIGINAL DESIGN

VASE

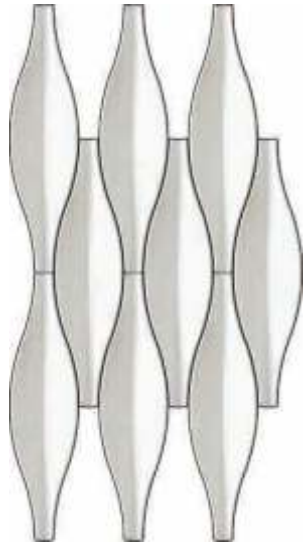

60 T WHITE

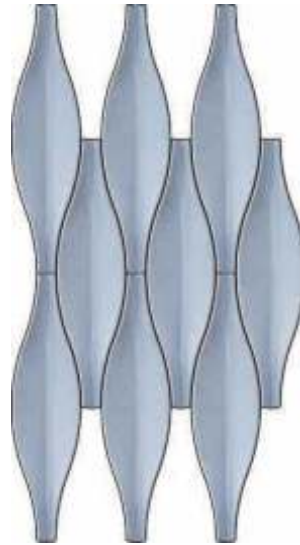

10 C BLUE

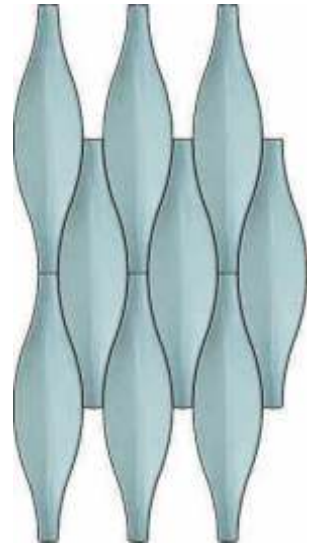

10 P GREEN

The hard cement texture matches the soft color for comfort. Nifty and unique vase shape highlights individual character. Can be used in porch place, also can make setting wall, even if do not delicate and charming like flower , vase itself also has very strong adornment effect.

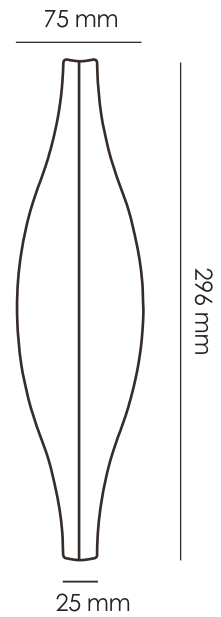



60 T-WHITE



10 S-GREY



10 C-GREY



30 C-GREY



10 F-BROWN

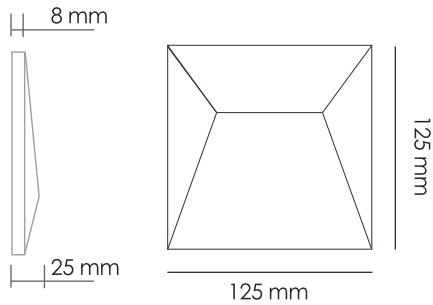

Inspired by the geometric nature of the original map, geometric design bold, given the distinct characteristic, the line of stereo administrative levels reflecting dynamic shadows, make metope is full of vitality, pure manual production to make each piece of tile has an interesting soul, full of fashion, high taste and style, make people enjoy unique space and strong sense of vision impact.

ORATOR

18



60 T-WHITE



10 S-GREY



10 C-GREY



30 C-GREY



10 F-BROWN

Inspired by the geometric nature of the original map, geometric design bold, given the distinct characteristic, the line of stereo administrative levels reflecting dynamic shadows, make metope is full of vitality, pure manual production to make each piece of tile has an interesting soul, full of fashion, high taste and style, make people enjoy unique space and strong sense of vision impact.

TRAY

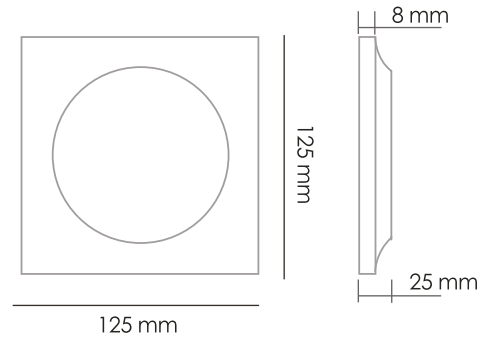



60 T-WHITE



05 C-GREY



10 C-GREY



30 C-GREY



10 C-BLUE

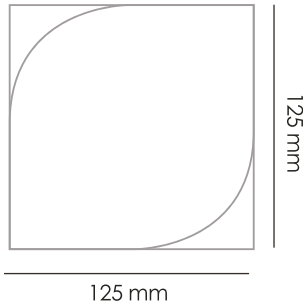

Inspired by the geometric nature of the original map, geometric design bold, given the distinct characteristic, the line of stereo administrative levels reflecting dynamic shadows, make metope is full of vitality, pure manual production to make each piece of tile has an interesting soul, full of fashion, high taste and style, make people enjoy unique space and strong sense of vision impact.

WAVE

20



60 T-WHITE



10 S-GREY



10 C-GREY



60 C-GREY



10 L-GREEN

Inspired by the geometric nature of the original map, geometric design bold, given the distinct characteristic, the line of stereo administrative levels reflecting dynamic shadows, make metope is full of vitality, pure manual production to make each piece of tile has an interesting soul, full of fashion, high taste and style, make people enjoy unique space and strong sense of vision impact.

DIDOT

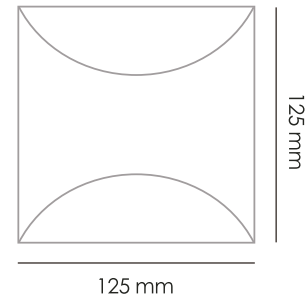



100



101

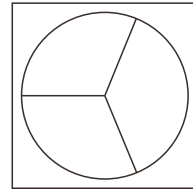
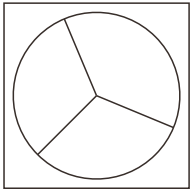
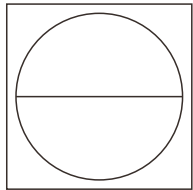
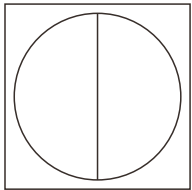
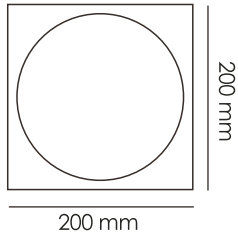
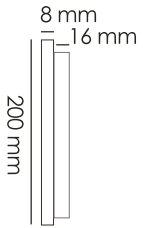

The design was inspired by the feeling of time flowing. The lines and three-dimensional contours of the clock bring a sense of space with the passage of time, presenting a unique artistic style, with a strong visual feeling and creative decoration, pleasing to the eye, becoming a landscape of the times.

21

HOUR HAND

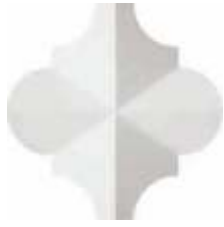

60T WHITE



UC WHITE

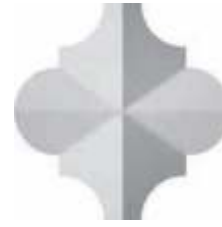

10C GREY



3D RED

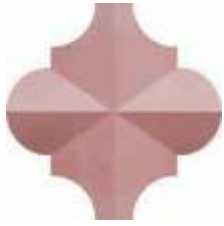

5D RED

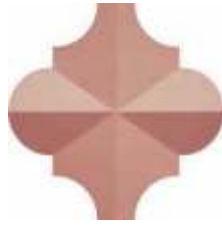

2T RED

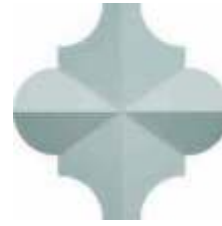

10P GREEN



10 BLUE

The symbolism of the lantern has been important throughout human history, leading people through darkness and revealing the beginning and end of a journey of light. Auspicious blessings, happy reunion, beautiful curve of the lantern, can not help but let people home full of beautiful fantasy, simple and bright color, natural and modern contrast and integration, to create an ideal environment style and rich sense of space. The different colors make the space more interesting. The eclectic design changes the plain, and the visual impression of exploration and innovation is more pursued..

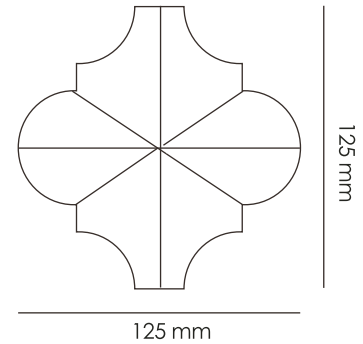

23

ORIGINAL DESIGN



60 T-WHITE



10 C-GREY



10 BLUE

SUPER SONIC

Designed by Michael Golden, an American designer, inspired by sound transmission, three kinds of texture tiles can be combined into hundreds of wall expressions. Suitable for commercial interiors to Hospitality spaces such as bars, restaurants, hotels, salons, clubs.

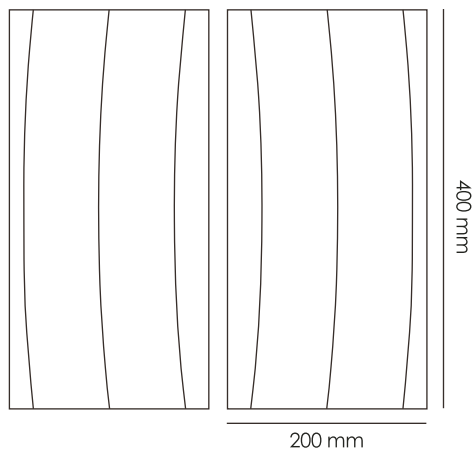

24

ORIGINAL DESIGN



60 T-WHITE



10 C-GREY



10 BLUE

SUPER SONIC

Designed by Michael Golden, an American designer, inspired by sound transmission, three kinds of texture tiles can be combined into hundreds of wall expressions. Suitable for commercial interiors to Hospitality spaces such as bars, restaurants, hotels, salons, clubs.

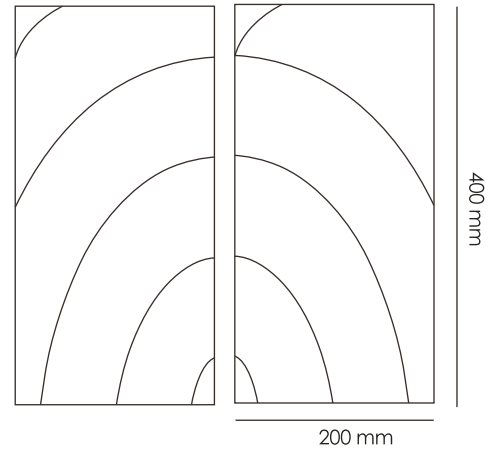



60T WHITE



10C GREY

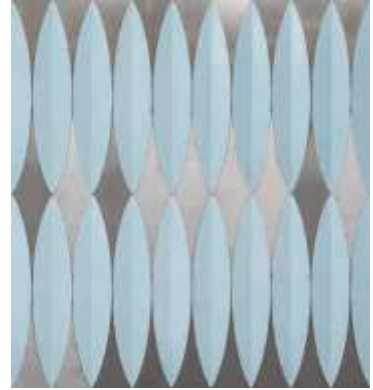

10 BLUE

Leaf series combine 2 units, mixed with metal materials, like stainless steel and aluminium. It create a luxury wall covering.

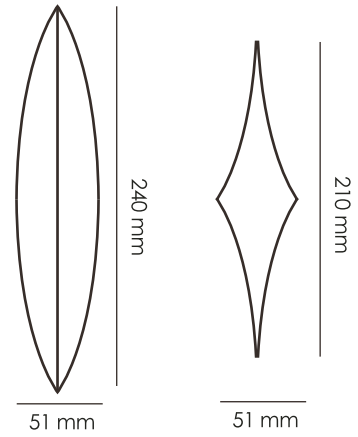

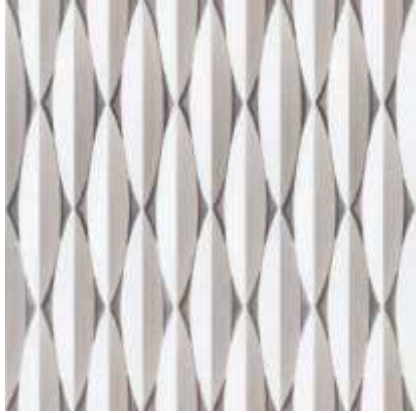

ST66+60T WHITE



ST66+60T MIX

Leaf series combine 2 units, mixed with metal materials, like stainless steel and aluminium. It create a luxury wall covering.

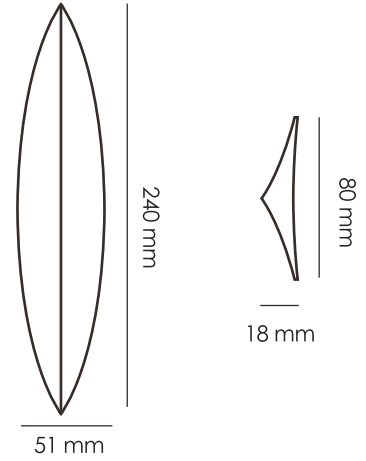

27



60 T WHITE



10 C GREY



10 S GREY



5M-BLUE

Inspiration comes from experiencing life, just like exploring in the maze tunnel, in the twists and turns of the unknown, constantly looking for the dawn of victory. The perfect use of geometric lines reflects the sense of intelligent design, unique three-dimensional style makes each tile more like a handicraft, full of high fashion sense, the design of not stick to one pattern changed the plain, more to pursue exploration and new impression, bring unique space enjoyment.

TUNNEL

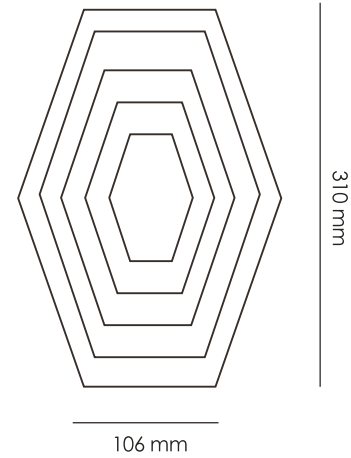



30 C GREY



30 C BLACK

Petal series, beautiful and delicate. The triangular shape gives people a firm, positive power. The cement texture is matched with the light petal shape, which is applied to different engineering scenes to change the dull and monotonous cement itself, giving people a fresh and fresh feeling.

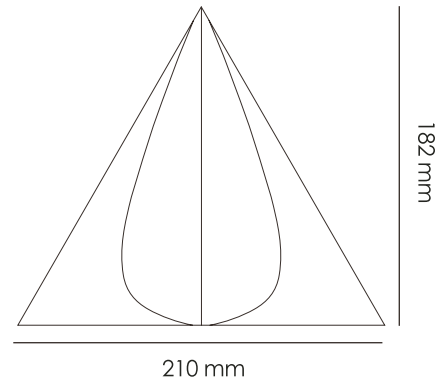

CONCAVE



60T WHITE



10C GREY

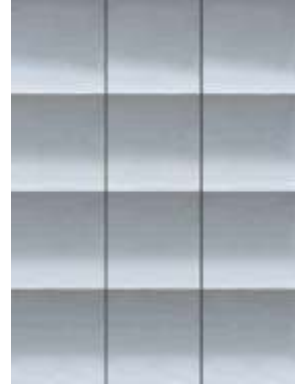

10 BLUE

Concave inspiration comes from the pursuit and fight to overcome the ups and downs of life. The elements of the wavy curve perfectly create the beauty of the space art, and the concave and convex design style presents the 3D of continuous undulation, revealing a kind of dynamic life of constant struggle. Beautiful curves, waves of ups and downs, the moment of passion, It adds fashion style to home, full of distinctive personality visual impact and bring extraordinary enjoyment.

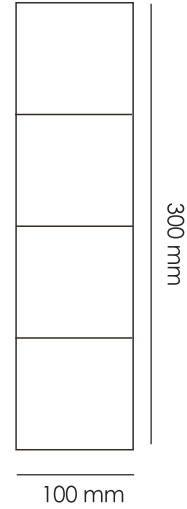



ZC-001



ZC-002



ZC-003

Inspiration comes from life that is like walking on a zebra crossing, many lines and crisscross, in the face of the unknown direction to choose, always have advance and retreat. Its unique 3D outline brings a thrilling sense of space, perfect lines intersection design shows a high-level sense of fashion, with extraordinary high taste of art style, it absolutely easy to absorb eyes and bring unique visual highlights for any space.

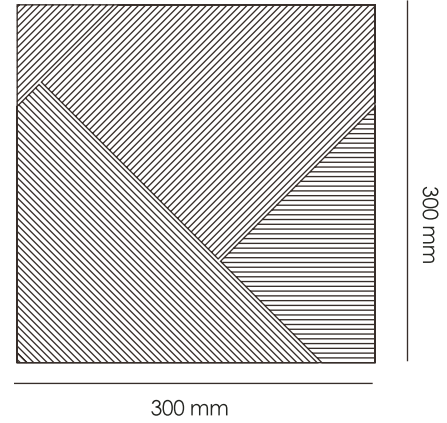



BM-001



BM-002



BM-003

To expect nothing from men, but to give it is an excellent thing. Concrete matched with the shape of bamboo indicates that we should be like bamboo in our life. We should keep our true colors, be strong, optimistic and fearless, live a straight life, and make ourselves the most beautiful scenery in our life.

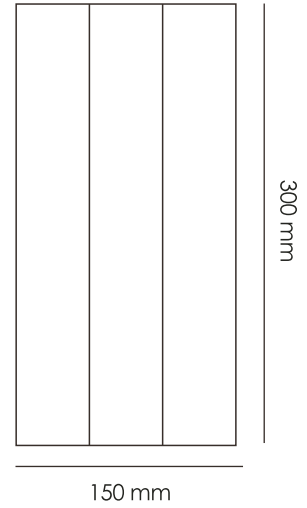



PN-001



PN-002



PN-003



PN-004



PN-005

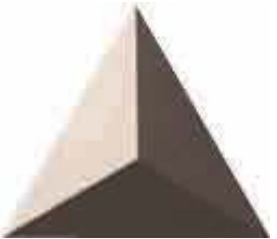

PN-006



PN-007



PN-008

POLYHEDRON

Every product is an embodiment of life attitude, Polyhedron, 3d and plane, four kinds of design, DIY can freely combine to meet different situational demands, life is always like this, full of imagination and infinite possibilities.

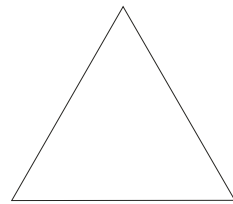

210 mm

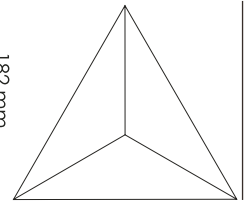

210 mm

182 mm

182 mm

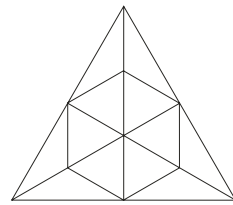

210 mm

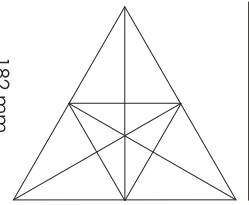

210 mm

182 mm

182 mm

